

# SERIES 96

## QUALITY ENGINEERED

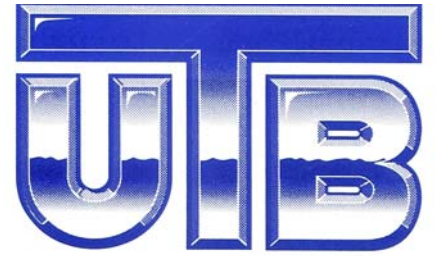

# Utility Bodies

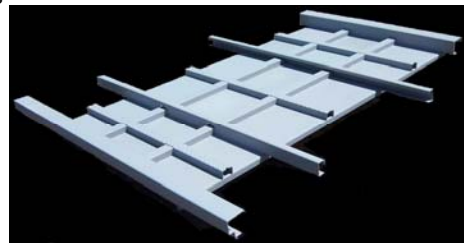
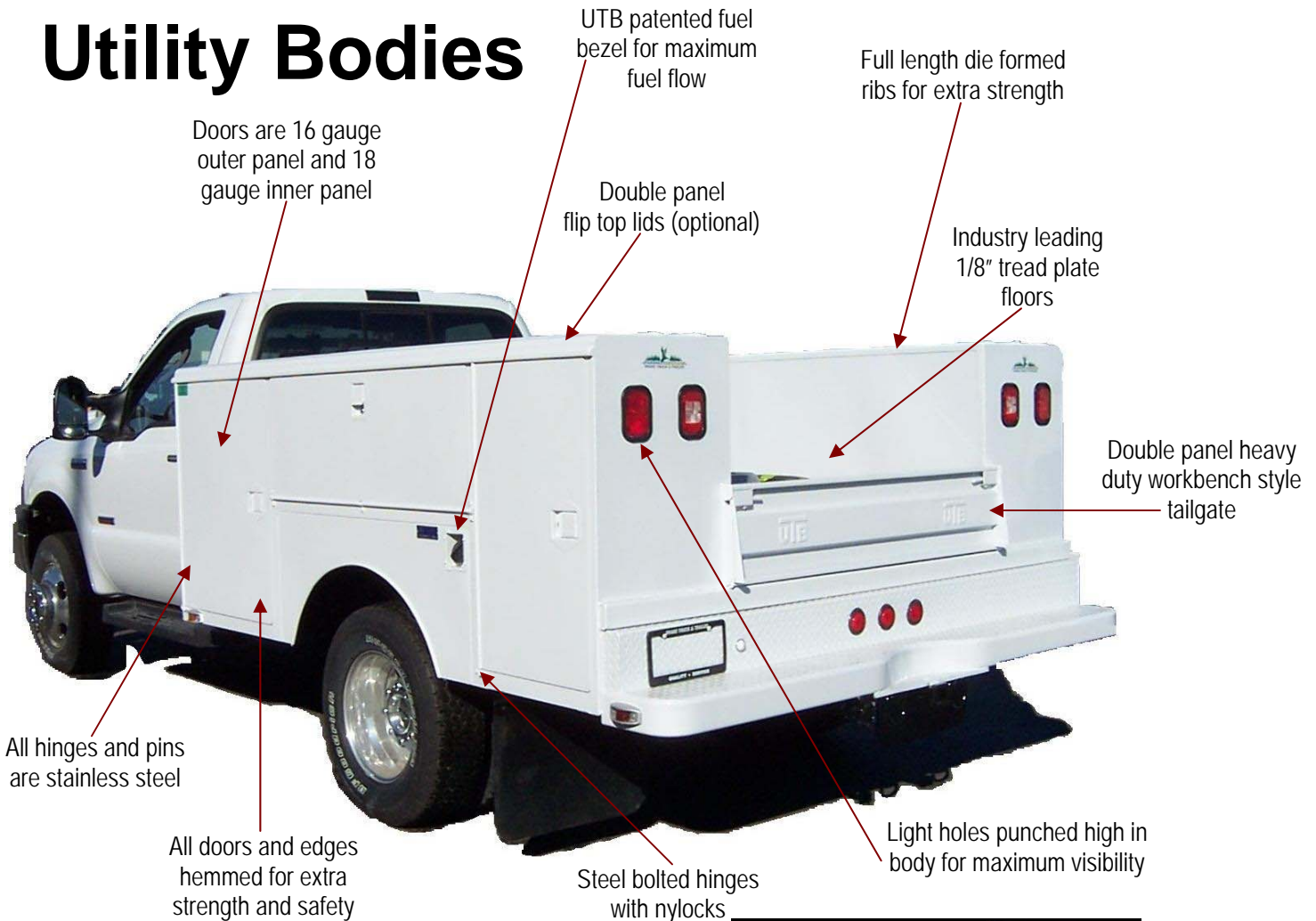

Patented interlaced understructure for maximum strength

**UTILITY...Our First Name For Over 50 Years**  
"Our 50 years of engineering, design and production experience assures customer satisfaction and continues to provide a standard for the industry."



**UNITED TRUCK BODIES** "Built to Work...Built to Last!"

2235 S. 19<sup>th</sup> Ave. Phoenix, AZ 85009 602-258-4223 Fax 602-258-4008 Email: [info@unitedtruckbodies.com](mailto:info@unitedtruckbodies.com)

# SERIES S-96

QUALITY ENGINEERED

		STANDARD HEIGHT	STANDARD HEIGHT LOWER REAR DR.S.	LOW PROFILE	LOW PROFILE LOWER REAR DR.S.
MODEL DESIGNATION		9642	9642	9636	9636
BODY HEIGHT	A	42"	42"	36"	36"
FLIP TOPS (OPTIONAL)	B	ADD "FT" AFTER MODEL DESIGNATION			
HORIZ. COMPT. HEIGHT	C	20"	20"	17"	17"
FLOOR TO COMPT. TOP	D	27¼"	27¼"	23¾"	23¾"
OVERALL BODY WIDTH	E	78½"	78½"	78½"	78½"
CLEAR DOOR OPENINGS		L X H	L X H	L X H	L X H
FRONT COMPARTMENT		28" X 34¼"	28" X 34¼"	28" X 28¼"	28" X 28¼"
HORIZ. COMPARTMENT		35½" X 15"	58" X 15"	35½" X 12"	58" X 12"
REAR COMPARTMENT		18" X 34¼"	18" X 15"	18" X 28½"	18" X 12"

### STANDARD COMPARTMENT INTERIORS:

FRONT VERTICALS.....2-ADJUSTABLE SHELVES  
 HORIZONTAL.....1-FIXED SHELF  
 REAR VERTICAL.....1-ADJUSTABLE SHELF

### OPTIONAL FEATURES:

CRANE REINFORCEMENTS  
 COMPRESSORS  
 PULL OUT DRAWERS  
 BOOK SHELVES  
 FLIP TOP COMPARTMENTS  
 THREE POINT LATCHES  
 VICE BRACKETS  
 TELESCOPIC ROOFS  
 RAISED SUPERSTRUCTURE ROOFS  
 BARN DOORS FOR SUPERSTRUCTURES  
 GENERATORS  
 CONE HOLDERS  
 SPOT LIGHTS & LIGHT BARS  
 CUSTOM BUMPERS  
 RAISED FRONT VERTICAL COMPARTMENTS  
 HOT STICK BOXES  
 LADDER RACKS

### STANDARD FEATURES:

INTERLACED UNDERSTRUCTURE  
 EVERY OPENING & EDGE HEMMED FOR STRENGTH AND SAFETY  
 BOOK SHELVES  
 FULLY UNDERCOATED  
 ALL DOORS HAVE HEAVY DUTY RESTRAINTS  
 AUTOMOTIVE BULB SEAL ON ALL DOORS

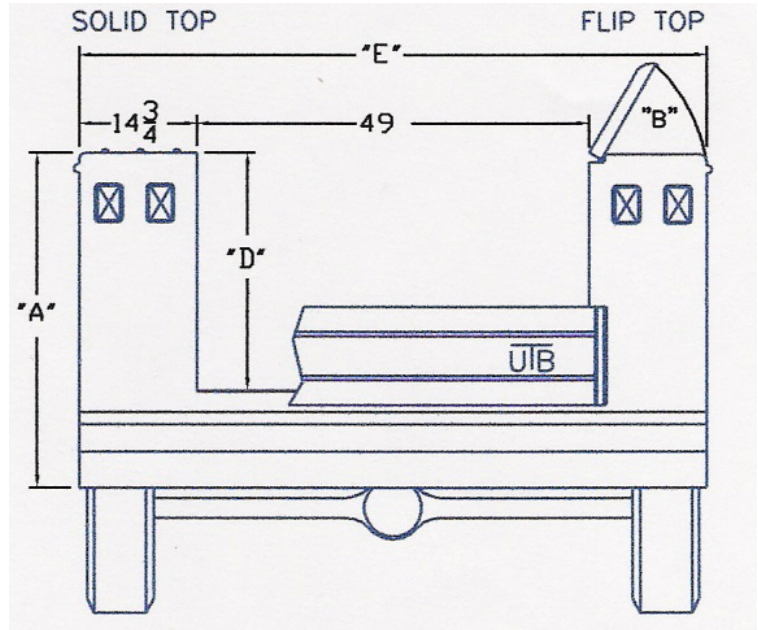
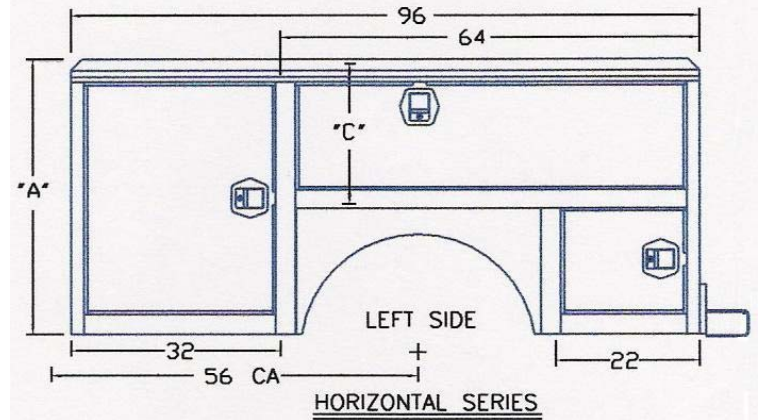
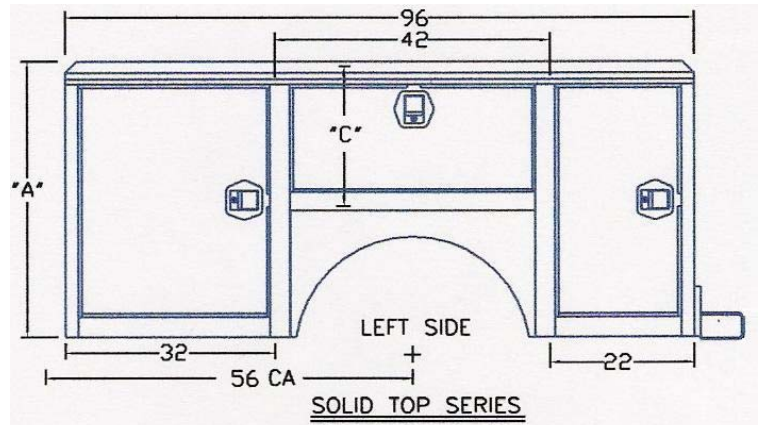

### GOING BEYOND YOUR EXPECTATIONS!



**FROM ¾ TON TO 2 TON, UTB COVERS ALL YOUR HEAVY DUTY SERVICE AND CRANE BODY NEEDS**

We invite you to visit UTB or one of our distributors to discuss your utility or field mechanic body requirements.

AVAILABLE FROM: