

SERIES 108

QUALITY ENGINEERED

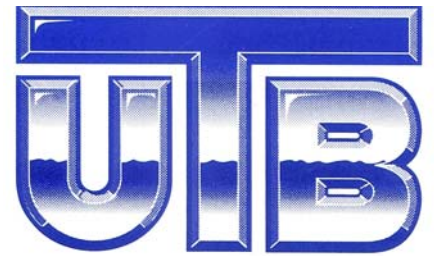

Utility Bodies

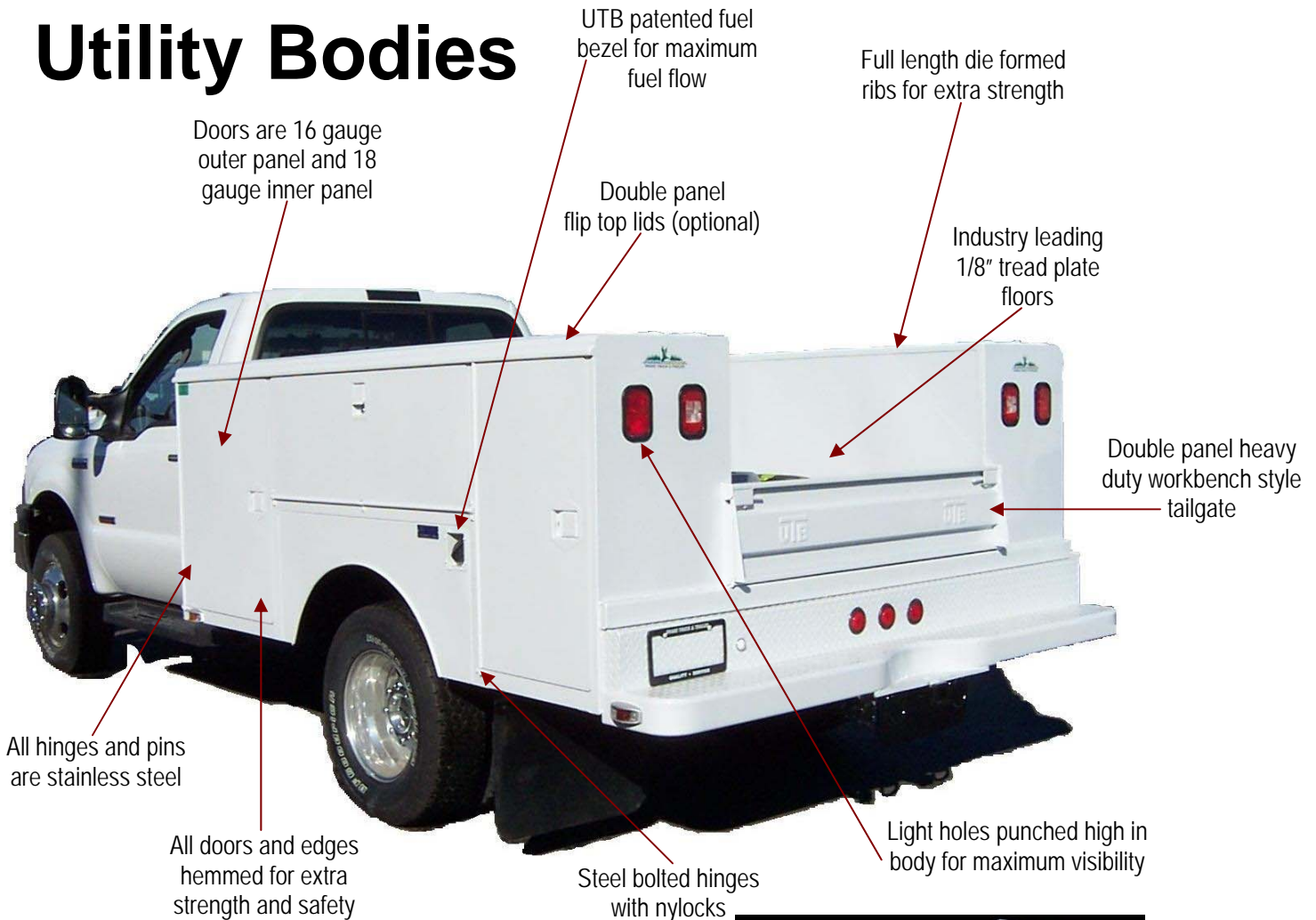

UTB patented fuel bezel for maximum fuel flow

Full length die formed ribs for extra strength

Doors are 16 gauge outer panel and 18 gauge inner panel

Double panel flip top lids (optional)

Industry leading 1/8" tread plate floors

Double panel heavy duty workbench style tailgate

All hinges and pins are stainless steel

All doors and edges hemmed for extra strength and safety

Steel bolted hinges with nylocks

Light holes punched high in body for maximum visibility

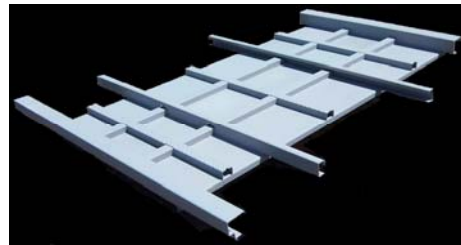

Patented interlaced understructure for maximum strength

UTILITY...Our First Name For Over 50 Years

"Our 50 years of engineering, design and production experience assures customer satisfaction and continues to provide a standard for the industry."



UNITED TRUCK BODIES

"Built to Work...Built to Last!"

2235 S. 19th Ave. Phoenix, AZ 85009 602-258-4223 Fax 602-258-4008 Email: info@unitedtruckbodies.com

SERIES S-108

QUALITY ENGINEERED

		STANDARD HEIGHT	STANDARD HEIGHT LOWER REAR DRS.	LOW PROFILE	LOW PROFILE LOWER REAR DRS.
MODEL DESIGNATION		10842	10842	10836	10836
BODY HEIGHT	A	42"	42"	36"	36"
FLIP TOPS (OPTIONAL)	B	ADD "FT" AFTER MODEL DESIGNATION			
HORIZ. COMPT. HEIGHT	C	20"	20"	17"	17"
FLOOR TO COMPT. TOP	D	29 $\frac{1}{4}$ "	29 $\frac{1}{4}$ "	23 $\frac{1}{4}$ "	23 $\frac{1}{4}$ "
OVERALL BODY WIDTH	E	94"	94"	94"	94"
CLEAR DOOR OPENINGS		L X H	L X H	L X H	L X H
FRONT COMPARTMENT		28" X 34 $\frac{1}{2}$ "	28" X 34 $\frac{1}{2}$ "	28" X 28 $\frac{1}{2}$ "	28" X 28 $\frac{1}{2}$ "
HORIZ. COMPARTMENT		47 $\frac{1}{2}$ " X 15 $\frac{1}{4}$ "	32 $\frac{3}{4}$ " X 15 $\frac{1}{4}$ "	47 $\frac{1}{2}$ " X 12 $\frac{1}{4}$ "	32 $\frac{3}{4}$ " X 12 $\frac{1}{4}$ "
REAR COMPARTMENT		18" X 34 $\frac{1}{2}$ "	18" X 15"	18" X 28 $\frac{1}{2}$ "	18" X 12"

STANDARD COMPARTMENT INTERIORS:

- FRONT VERTICALS.....2-ADJUSTABLE SHELVES
- HORIZONTAL.....1-FIXED SHELF
- REAR VERTICAL.....1-ADJUSTABLE SHELF

OPTIONAL FEATURES:

- CRANE REINFORCEMENTS
- COMPRESSORS
- PULL OUT DRAWERS
- BOOK SHELVES
- FLIP TOP COMPARTMENTS
- THREE POINT LATCHES
- VICE BRACKETS
- TELESCOPIC ROOFS
- RAISED SUPERSTRUCTURE ROOFS
- BARN DOORS FOR SUPERSTRUCTURES
- GENERATORS
- CONE HOLDERS
- SPOT LIGHTS & LIGHT BARS
- CUSTOM BUMPERS
- RAISED FRONT VERTICAL COMPARTMENTS
- HOT STICK BOXES
- LADDER RACKS

STANDARD FEATURES:

- INTERLACED UNDERSTRUCTURE
- EVERY OPENING & EDGE HEMMED FOR STRENGTH AND SAFETY
- BOOK SHELVES
- FULLY UNDERCOATED
- ALL DOORS HAVE HEAVY DUTY RESTRAINTS
- AUTOMOTIVE BULB SEAL ON ALL DOORS

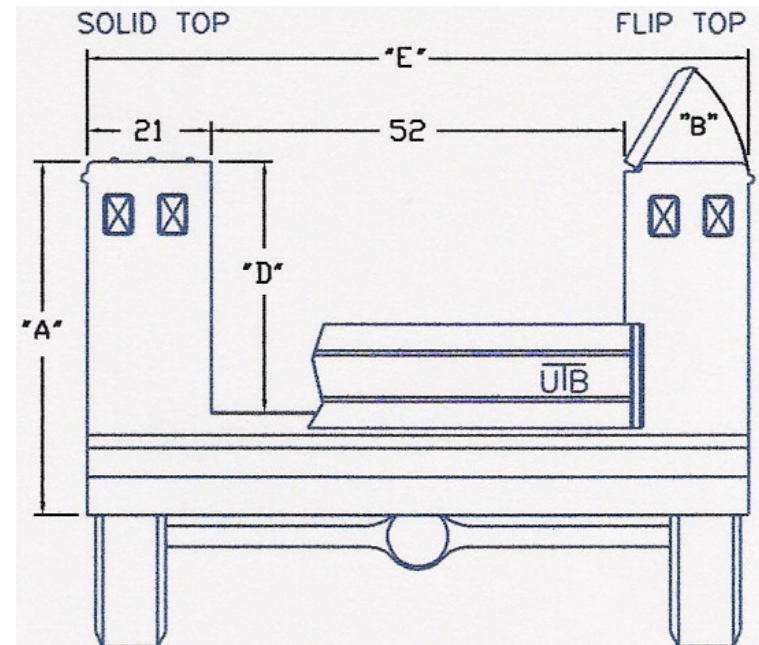
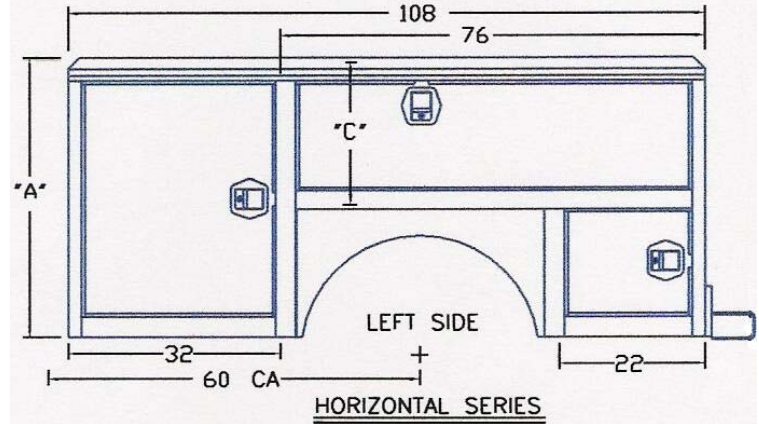
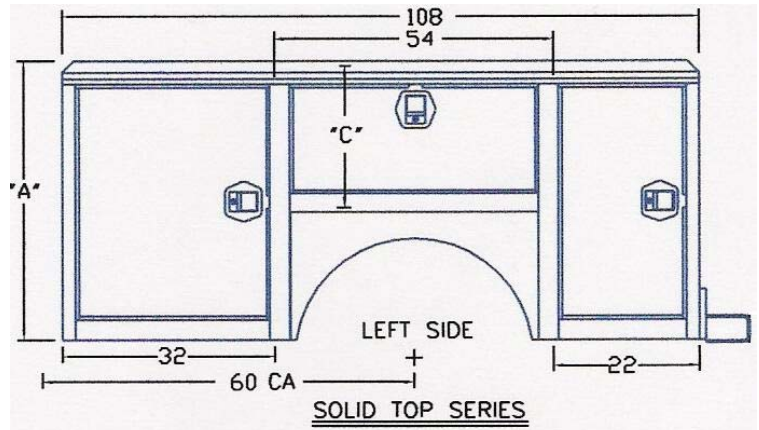

GOING BEYOND YOUR EXPECTATIONS!



FROM 3/4 TON TO 2 TON, UTB COVERS ALL YOUR HEAVY DUTY SERVICE AND CRANE BODY NEEDS

We invite you to visit UTB or one of our distributors to discuss your utility or field mechanic body requirements.

AVAILABLE FROM: